

Edition : 1.0
Date: (03/26)

Instruction Manual

6 Drawer **INDUSTRIAL MOBILE TOOLING CABINET** **TCW-900N**

Order Code: (T765)

BEFORE ASSEMBLING

Please read this instruction manual before assembly.



CAUTION

Before assembly please pay attention to the following points in priority;

Confirmation of components: Before assembling, please confirm all parts arrived and are in good order.

Site for assembly: Please assemble it on the soft floor such as smooth carpet and flannel blanket. When you assemble on wooden floor, please put thin towels on the floor.

Points for attention when assembling: Please wear gloves to ensure that it can be assembled safely, and use two persons to help in the assembly process.

Matters needing attention for operation:

- Do not use for in proper use.
- Do not use it on inclined surface or uneven places.
- Do not use it when screws and fasteners are loosened.

Maintenance

Keep drawer runners and rollers clean and free of debris.

Apply a dry lubricant regularly to ensure smooth operation and maximise service life.

Do not use oil-based lubricants, as they may attract dust and reduce performance.

Load Capacity & Usage

Maximum load per drawer: 100kg

Maximum cabinet load: 600kg

Do not exceed rated capacities, as this may:

Damage drawer runners

Compromise safety

Void warranty

Safety Precautions

Do not open multiple drawers at once.

Do not climb, stand, or sit on the cabinet or drawers.

Always distribute weight evenly within drawers.

Always use the cabinet on a level, solid surface to prevent it from rolling away unexpectedly.

Keep heavier items in lower drawers to maintain stability.

Ensure drawers are fully closed and key locked before moving the cabinet.

Ensure the wheels are locked when the cabinet is in position to prevent it from rolling away unexpectedly.

Optional Top Surface Use

If using the optional backing panel and rubber mat:

Use it to safely rest tools and components.

Avoid overloading the top surface beyond recommended limits.

TOOLS REQUIRED FOR ASSEMBLY

- Spanners
- Phillips Head Screwdriver

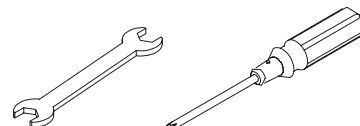

PARTS LIST

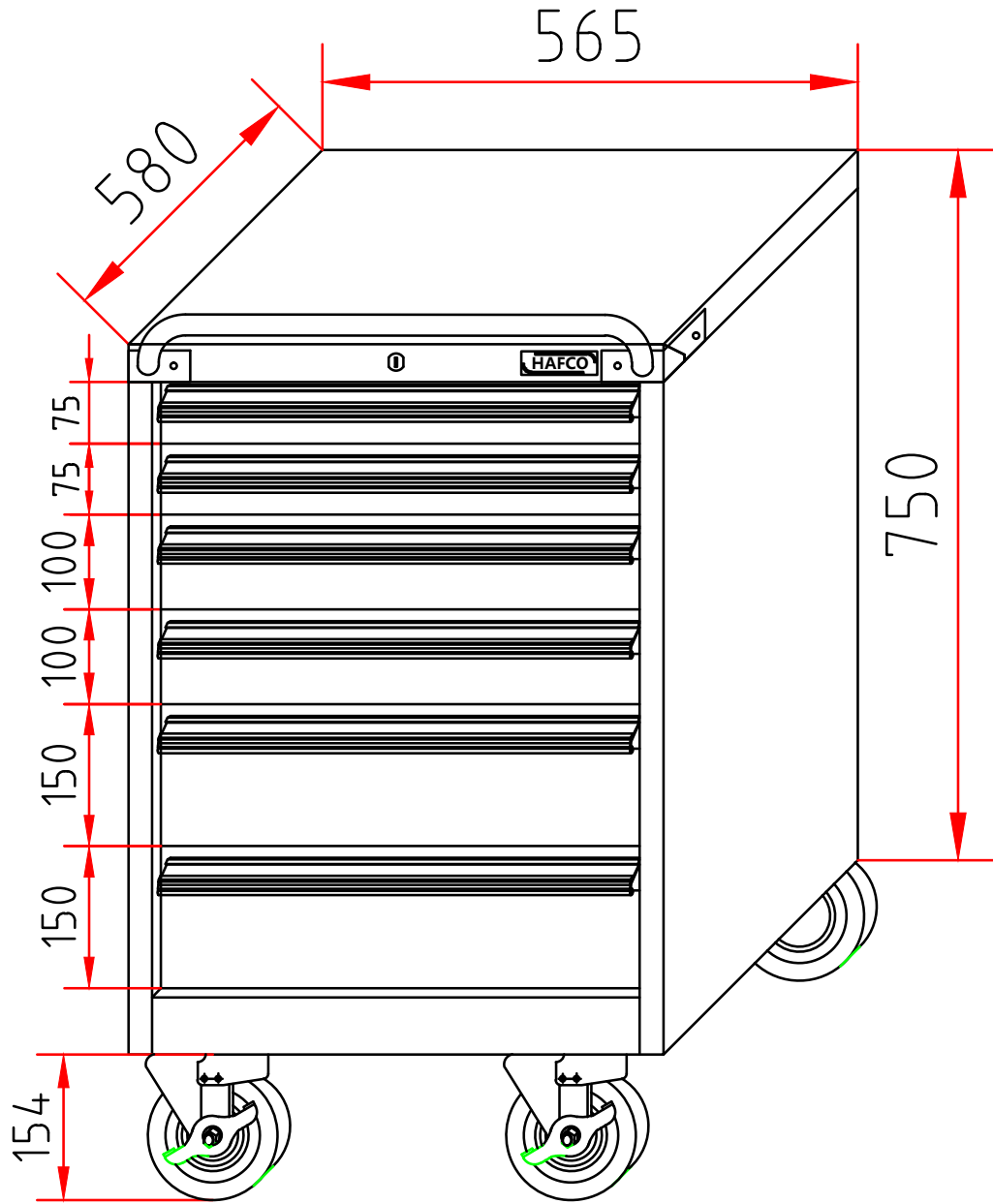

Description	Qty
Cabinet	1
75mm Drawer with Assorted Buckets	1
75mm Drawer with Dividers	1
100mm Drawer with Dividers	2
150mm Drawer with Dividers	2
Ø125mm Swivel Caster Wheels with Brake	2
Ø125mm Fixed Caster Wheels	2
Push Handle	1

Operating Instructions & Safety Guidelines

General Operation

- When the tooling cabinet is unlocked, only one drawer can be opened at a time.
- This safety feature prevents the cabinet from tipping forward under load.
- Always ensure the cabinet is placed on a level and stable surface before use.

Drawer Removal

- 1 Fully extend the drawer.
- 2 Tilt the front of the drawer upward.
- 3 Lift the drawer up and out over the rollers.

When reinstalling, align the drawer with the rails and gently slide it back into position.

Drawer Safety Lock System

- Each drawer is fitted with a mechanical safety lock latch connected to the drawer handle.
- The lock latch mechanism is located on the left-hand side of each drawer.
- When the drawer is closed, the latch automatically drops over a bracket mounted on the inside left wall of the cabinet, locking the drawer in place until it is released using the front handle.
- This system ensures that only one drawer can be opened at a time, improving safety and preventing the cabinet from tipping.

Cabinet Locking System

The cabinet features a single key locking system for secure storage.

Always lock the cabinet when not in use to:

- Prevent unauthorised access
- Avoid accidental drawer opening

Rear Locking Mechanism (Tip Safety)

Tilting the cabinet while it is unlocked may engage the rear locking mechanism.

If this occurs:

1. Insert a long, flat object (e.g. ruler or steel strip) into the rear mechanism area.
2. Carefully rotate or slide the mechanism back to the unlocked position.



Safe Movement & Positioning

- Ensure all drawers are fully closed before moving the cabinet.
- Lock the cabinet using the key prior to movement.
- Move the cabinet slowly and only on level, solid surfaces.
- Once in position, engage the brakes on the swivel caster wheels to prevent movement.
- Always ensure the wheels are locked when the cabinet is stationary to prevent it from rolling away unexpectedly.

Wheel Assembly

1. Carefully place the cabinet on its back or side on a soft, stable surface to avoid damage.
2. Identify the caster types:
 - 2 × fixed wheels (non-swivel)
 - 2 × swivel brake caster wheels
3. Attach the fixed wheels to the rear of the cabinet base using the supplied bolts.
4. Attach the swivel brake caster wheels to the front of the cabinet base using the supplied bolts.
5. Tighten all bolts securely and ensure each wheel is firmly mounted before returning the cabinet to an upright position.

Handle Assembly

1. Position the handle on the top front side of the cabinet.
2. Align the handle holes with the pre-tapped mounting holes.
3. Insert the supplied bolts through the handle into the cabinet.
4. Tighten all bolts securely using the appropriate tool.
5. Ensure the handle is firmly attached before moving or using the cabinet.



ENVIRONMENT PROTECTION

Recycle unwanted materials instead of disposing of them as waste. All tools, accessories and packaging should be sorted, taken to a recycling centre and disposed of in a manner which is compatible with the environment. When the product becomes completely unserviceable and requires disposal, drain any fluids (if applicable) into approved containers and dispose of the product and fluids according to local regulations.

Imported by

HARE & FORBES
MACHINERYHOUSE

Australian Distributor

Hare & Forbes
Machineryhouse
Sydney - Melbourne
Adelaide - Brisbane - Perth

Ph: 1300 202 200
www.machineryhouse.com.au

MACHINERYHOUSE

New Zealand Distributor

Machineryhouse
Auckland
Christchurch

Ph: 0800 142 326
www.machineryhouse.co.nz